



永弘源精密機械股份有限公司
台灣高速精密臥加第一品牌



CONTENTS

01 公司概況

02 優勢產品

03 產品應用領域

04 全球行銷

05 聯絡我們

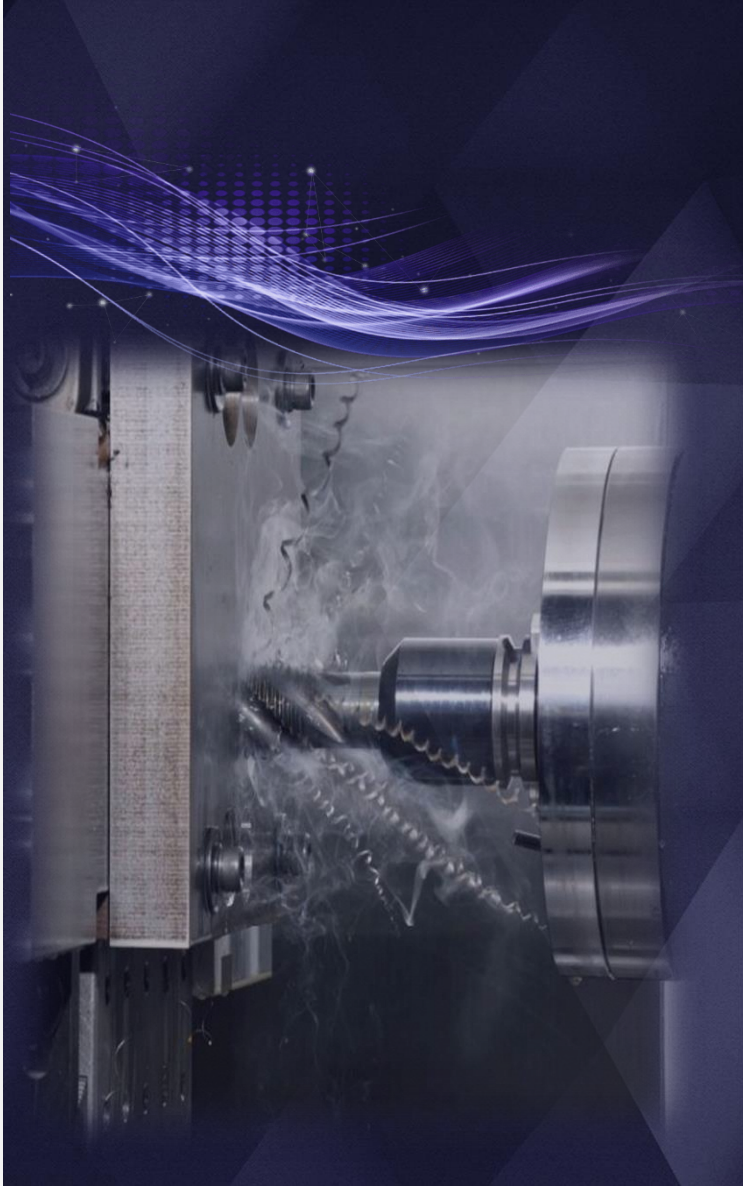



公司概況



永弘源精密機械成立於2006年，位於台灣中部的台中工業區，是台灣高速臥式綜合加工機第一品牌的製造廠。

本公司為台灣唯一單一生產高剛性、高速高精度臥式綜合加工機的專業製造廠，具備豐富的設計、製造、行銷、服務等全方位技術及經驗，全系列機種均可於廠外擴充多工作台及刀庫，產品熱烈行銷全世界，廣受顧客肯定。



01

公司概況



品質政策

「 追求完美品質，創造領導品牌 」

The CNC Professionals

本公司經營團隊的每位成員，都具備二十年以上豐富的
工具機產銷資歷，堅持追求完美的產品品質。



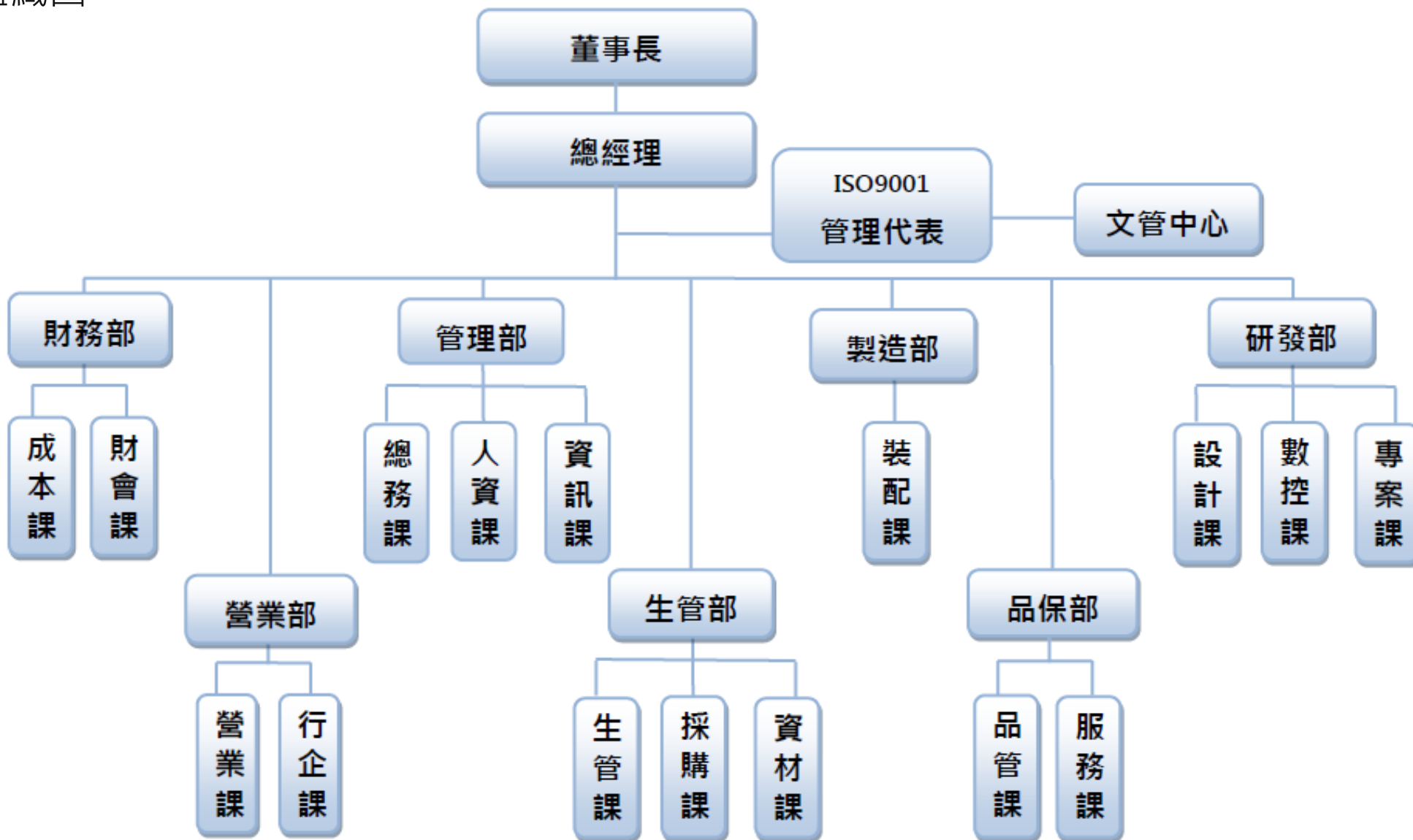

公司沿革

CE安全認證 & ISO 9001:2015認證



2010年通過CE安全規範



2012年取得ISO 9001:2008認證

2015年取得ISO 9001:2015認證





優勢產品

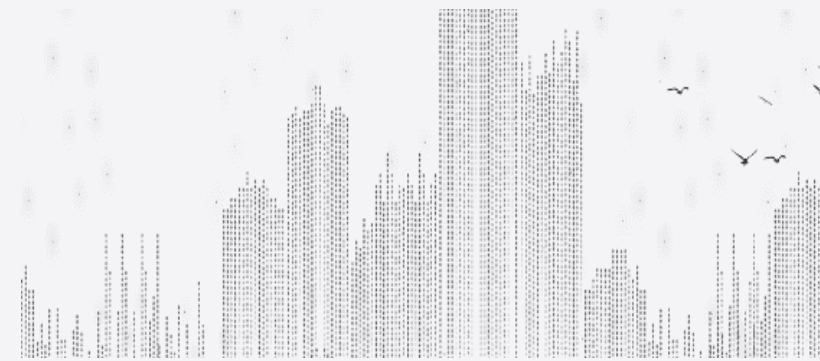

02

優勢產品

全系列機種



HS-450系列

#40主軸 400, 500mm工作台



HS-540系列

#40主軸 500, 400mm工作台

HS-550系列

#50主軸 500, 400mm工作台

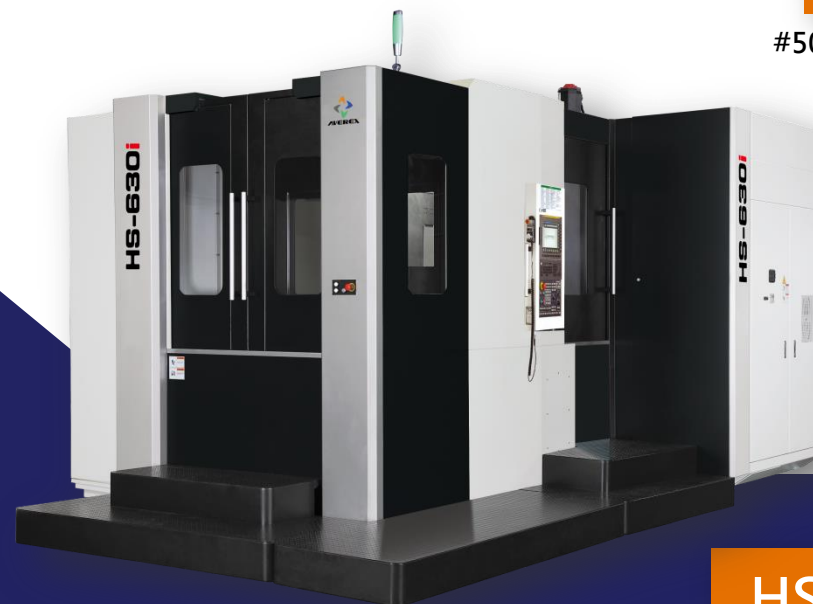

HS-630系列

#50主軸 630mm工作台

02

優勢產品

高剛性設計

整機接觸面
完全超精密級手工鏟花



一體鑄造底座 X軸高低軌
三點支撐設計

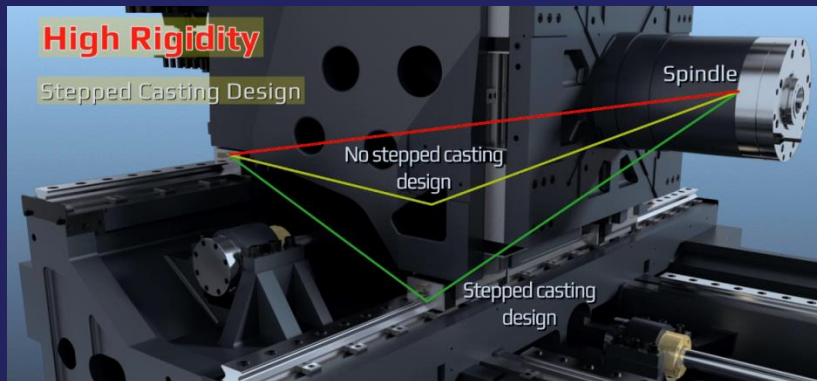
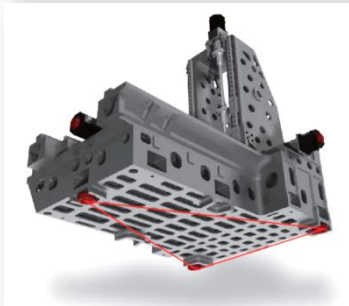

02

優勢產品

高剛性設計

底座及機身中空肋設計

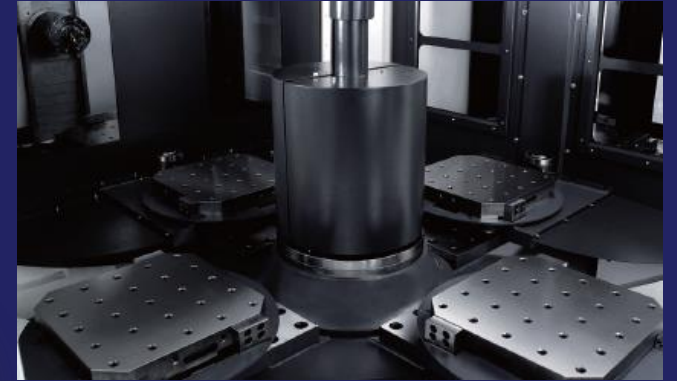
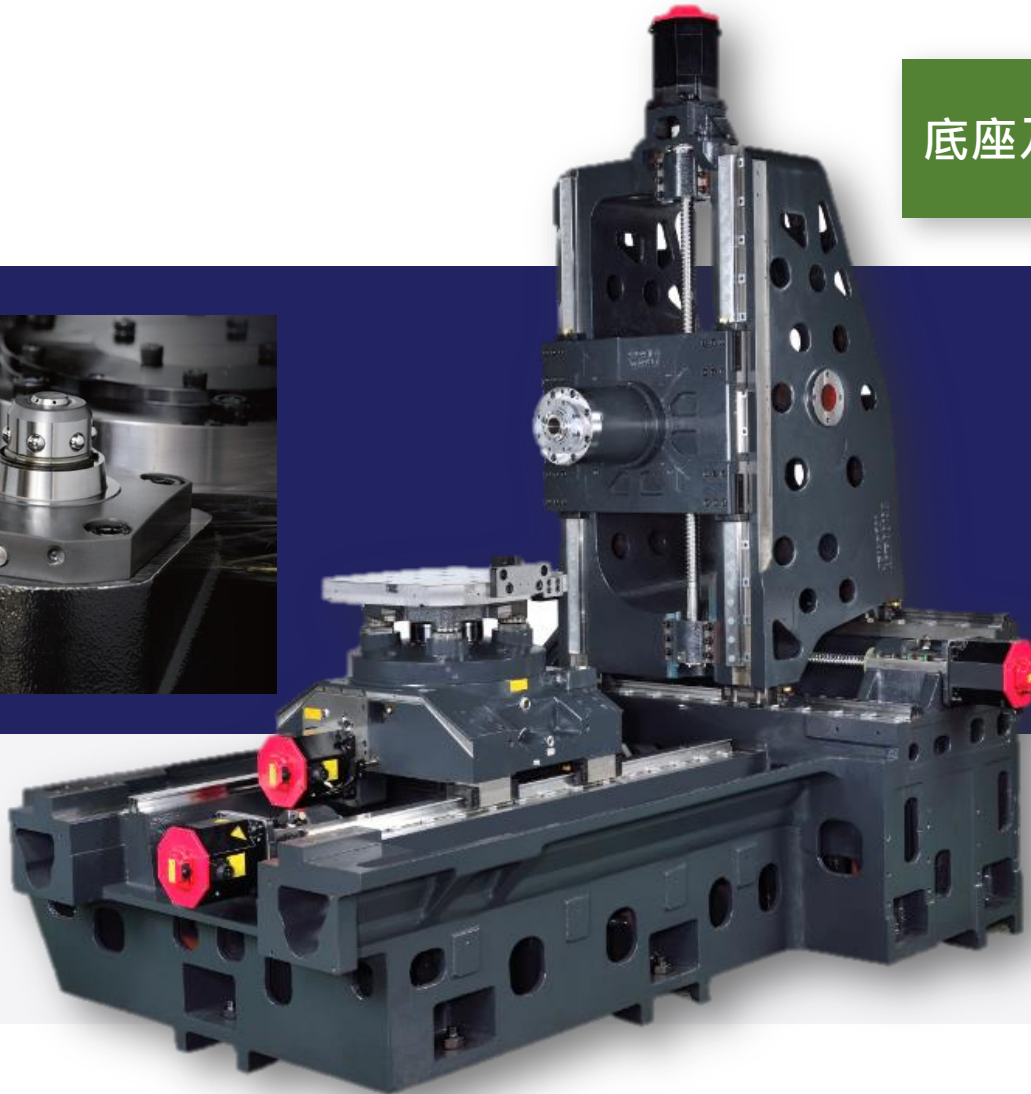

日本製
THK®高防護滾柱線軌
TSUBAKI®高精度螺桿

機型	主軸轉速 rpm	快速進給 m/min	切削進給 m/min	轉台轉速 rpm	ATC 秒	APC 秒
HS-450k/i HS-540k (BBT40)	15,000	60	60	33.3	1	5
HS-550k (BBT50)	10,000	1G			2.2	
HS-540i GTS (BBT40)	15,000	74	60	66.6	1	5
HS-550i GTS (BBT50)	10,000	1G			2.2	
HS-630i (BBT50)	10,000	50 1G	50	33.3	2.5	8

定位精度及重複定位精度

量測標準規範	ISO 10791-4	HS-450 / 540 / 550 系列
量測行程	全行程	全行程
定位精度	0.025 mm [0.00098"]	0.0050 mm [0.00019"]
重複定位精度	0.015 mm [0.00059"]	0.0028 mm [0.00011"]

HS-450/540 系列



循環度: 4.8 μm

進給速度
半徑 1,000 mm/min [39.4 ipm]
150 mm [5.9"]

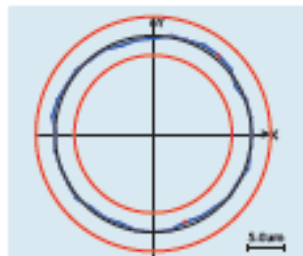

真圓度: 3.3 μm

材質 AL 6061 (Ø108 mm) [Ø4.25"]
刀具 Ø20 mm (3T) [Ø0.79"] (3T)
主軸轉速 4,777 rpm
進給速度 1,453 mm/min [57.2 ipm]

HS-550 系列

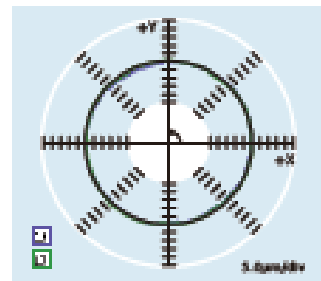

循環度: 4.8 μm

進給速度
半徑 1,000 mm/min [39.4 ipm]
150 mm [5.9"]

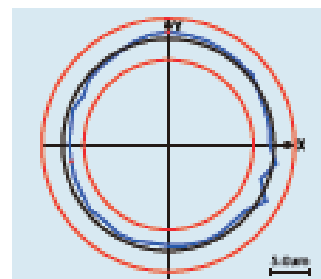

真圓度: 3.8 μm

材質 AL 6061 (Ø150 mm) [Ø5.9"]
刀具 Ø20 mm (3T) [Ø0.79"] (3T)
主軸轉速 4,777 rpm
進給速度 1,453 mm/min [57.2 ipm]

HS-450/540系列

249Nm / 37kw (15,000rpm)
287Nm / 48kw (12,000rpm)

HS-550系列

568Nm / 30kw (10,000rpm)

HS-630系列 (內藏式主軸)

600Nm / 45kw (10,000rpm)
1,200Nm / 55kw (8,000rpm)

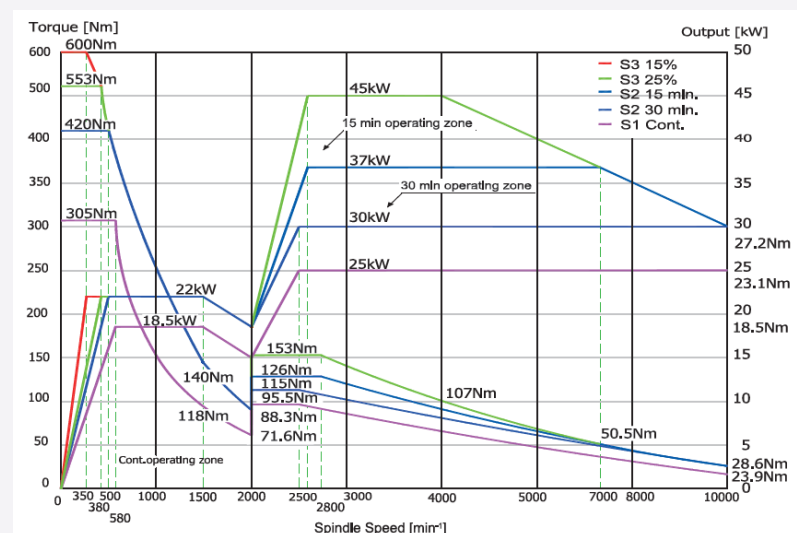
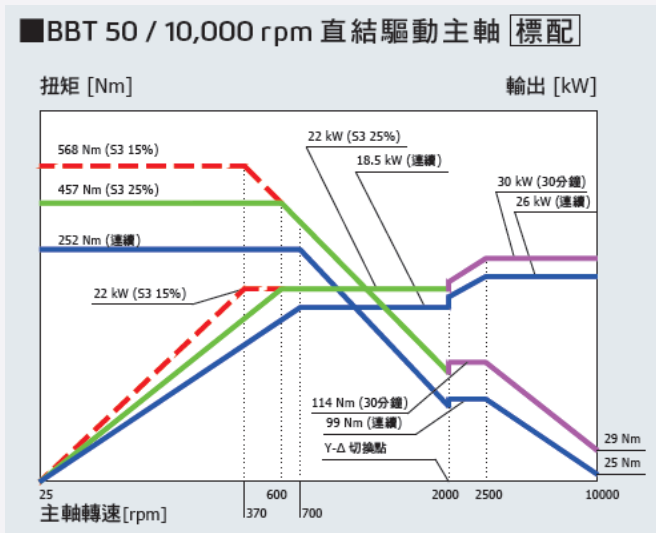
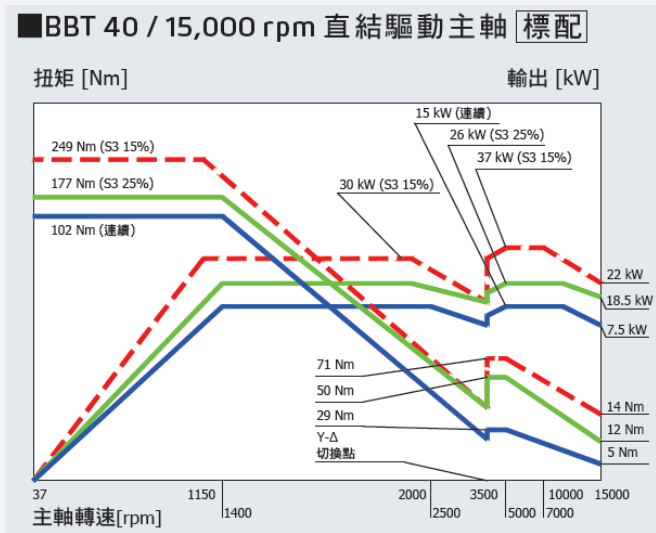



6APC iHMI 人機操作



8APC iHMI 人機操作



ATC iHMI 人機操作

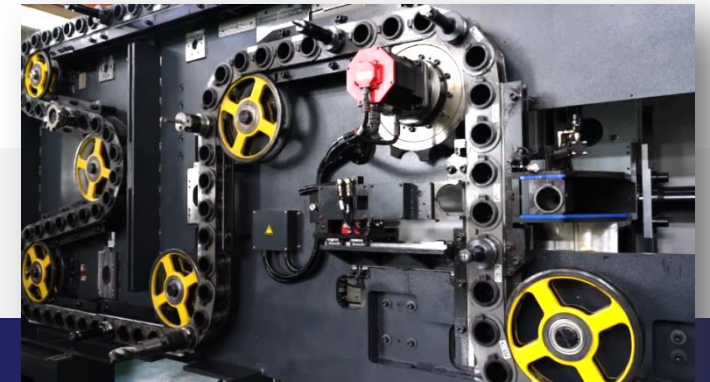

優勢產品

全系列機種均可於廠外擴充6APC, 8APC 工作臺

6工作臺
擴充組



2工作臺
本機



6工作臺
機台

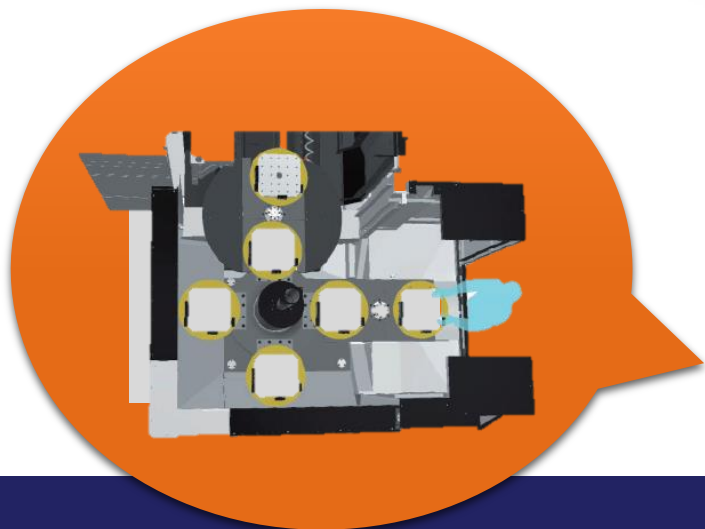

HS-4, 5全系列機種均可於廠外擴充刀庫

HS-450i / HS-540i GTS

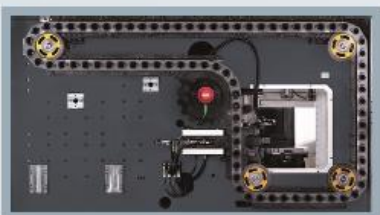

80刀 刀庫 標配



120刀 刀庫 選配



220刀 刀庫 選配

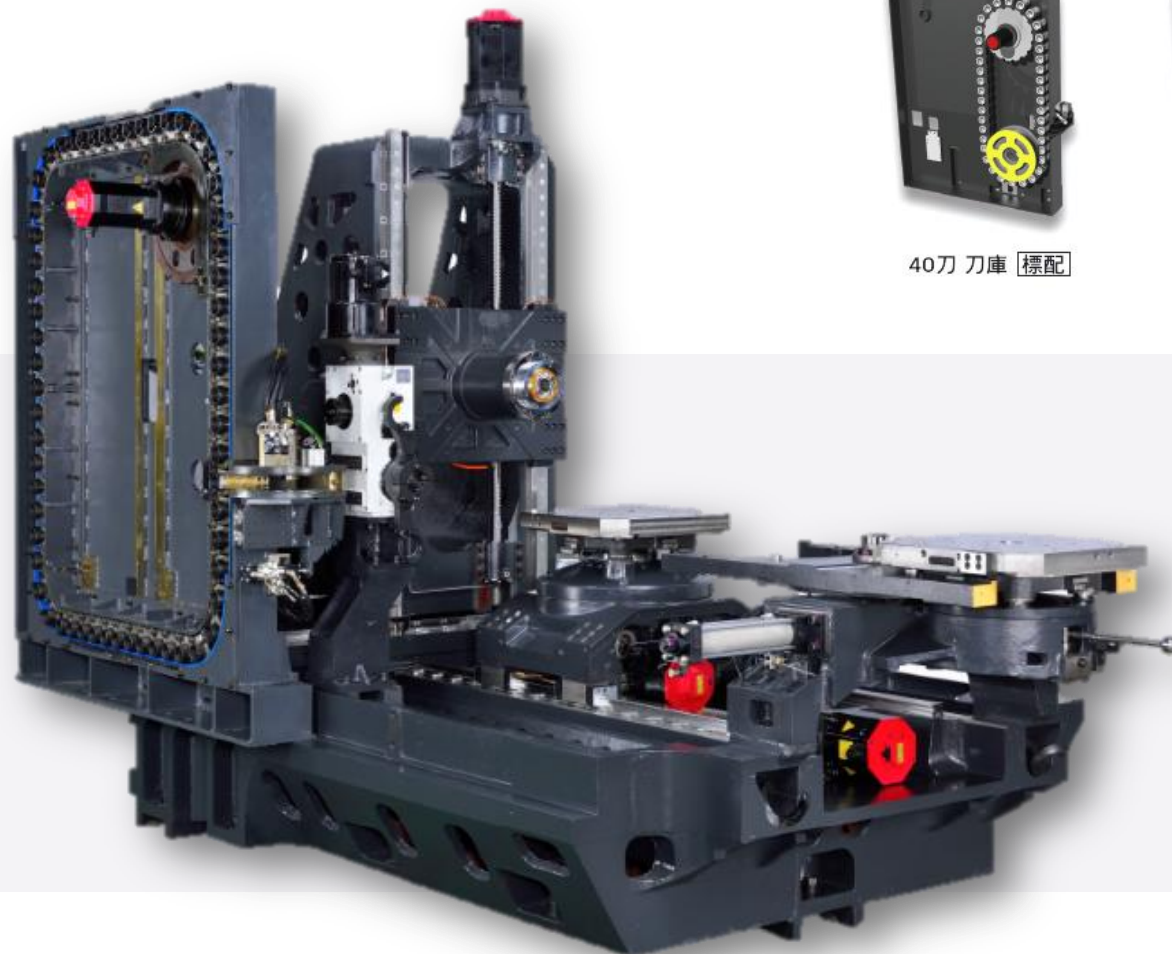

HS-450k / HS-540k



40刀 刀庫 標配



60刀 刀庫 選配



80刀 刀庫 選配

HS-550 系列



60刀 刀庫 標配



80刀 刀庫 選配



100刀 刀庫 選配

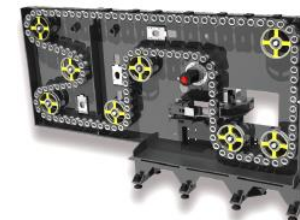

120刀 刀庫 選配

全系列機種均具備自動化選配

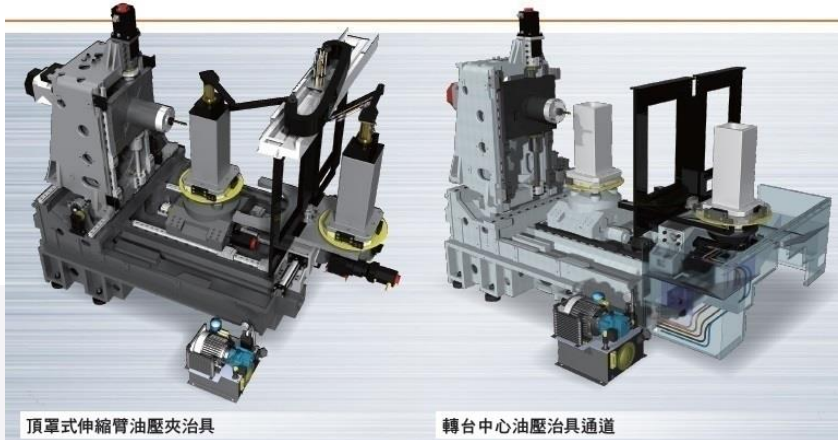

工件夾鬆氣密檢知

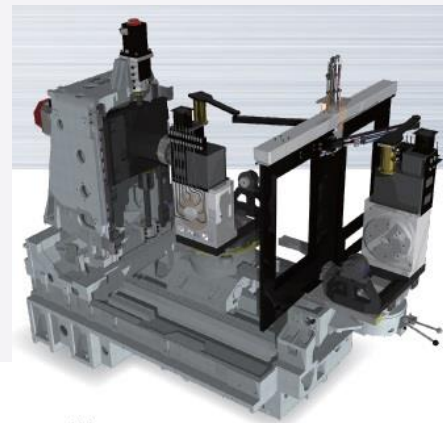

4+1軸加工

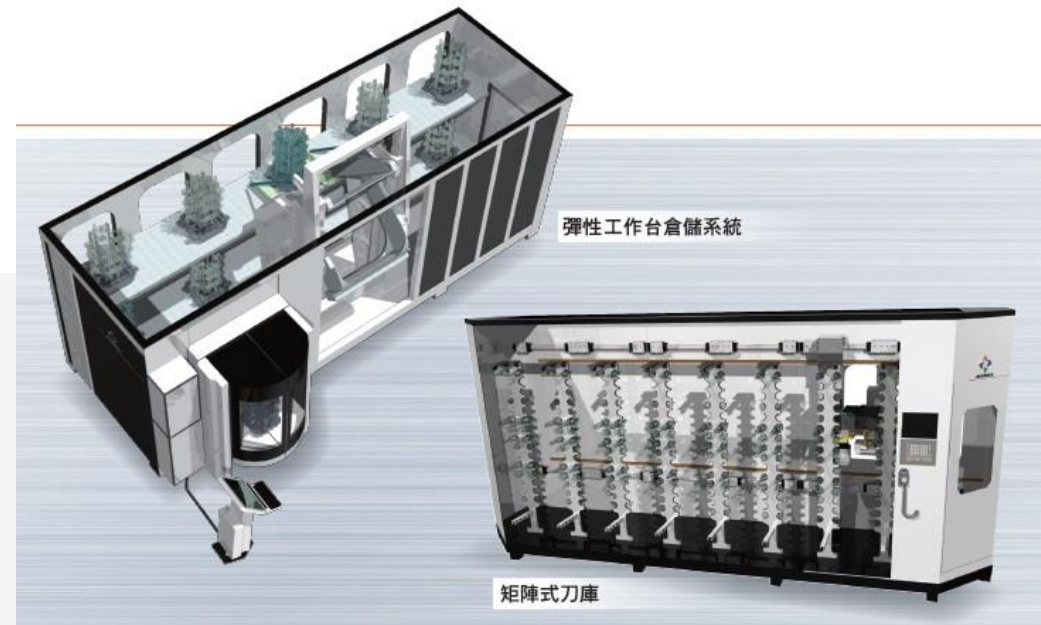

優勢產品

高效能除屑及高壓出水系統

AZUUS F1 渦漩除屑過濾系統

AZUUS F2 變頻高壓切削冷卻及除屑過濾系統 (可選配水箱冷卻系統)

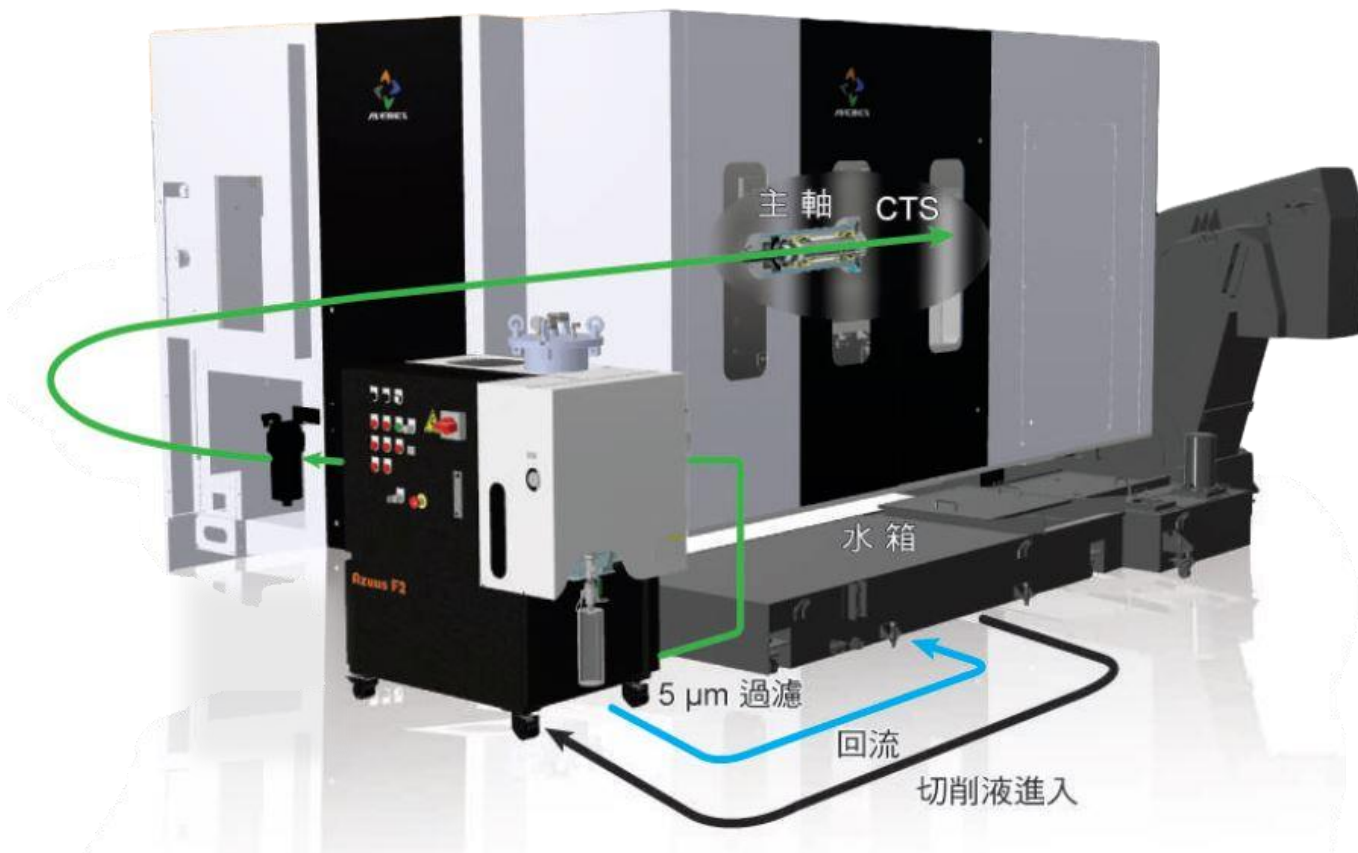

02

優勢產品

全系列機種15"彩色LCD 螢幕+iHMI 智能人機介面



02

優勢產品

旗艦機種

HS-540i GTS



15,000轉
/249Nm/37kw
高速高扭力
油氣潤滑主軸



中空油冷滾珠螺桿
XYZ軸800mm超大行程
工件旋徑800mm



三軸1G加速度
快速進給74 m/min



工作台旋轉速度
66.6rpm



1秒快速自動換刀系統
5秒交換工作台

03

產品應用領域

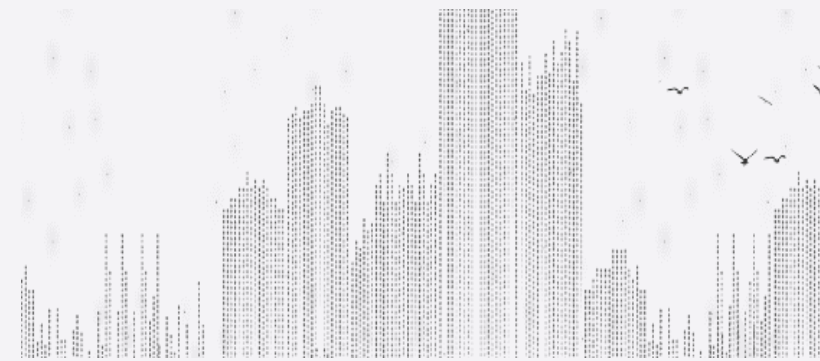

航太工業



能源產業



國防工業



汽車工業



生醫產業



農機產業



自動化產業

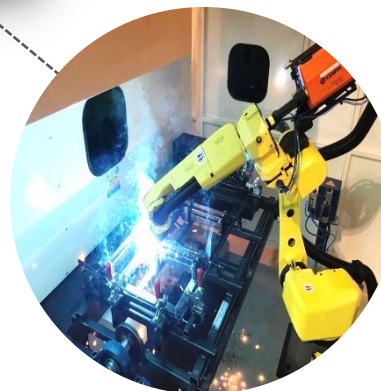

04

全球行銷

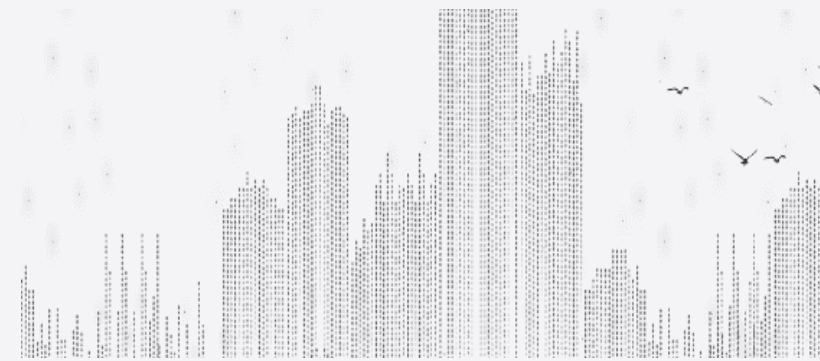



永弘源精密機械自2010年開始銷售迄今，超過500台以上臥式綜合加工機的銷售實績，優質管控的產品廣受全球顧客肯定。

04

全球行銷

完整的全球行銷及服務

美洲

歐洲

亞洲

台灣

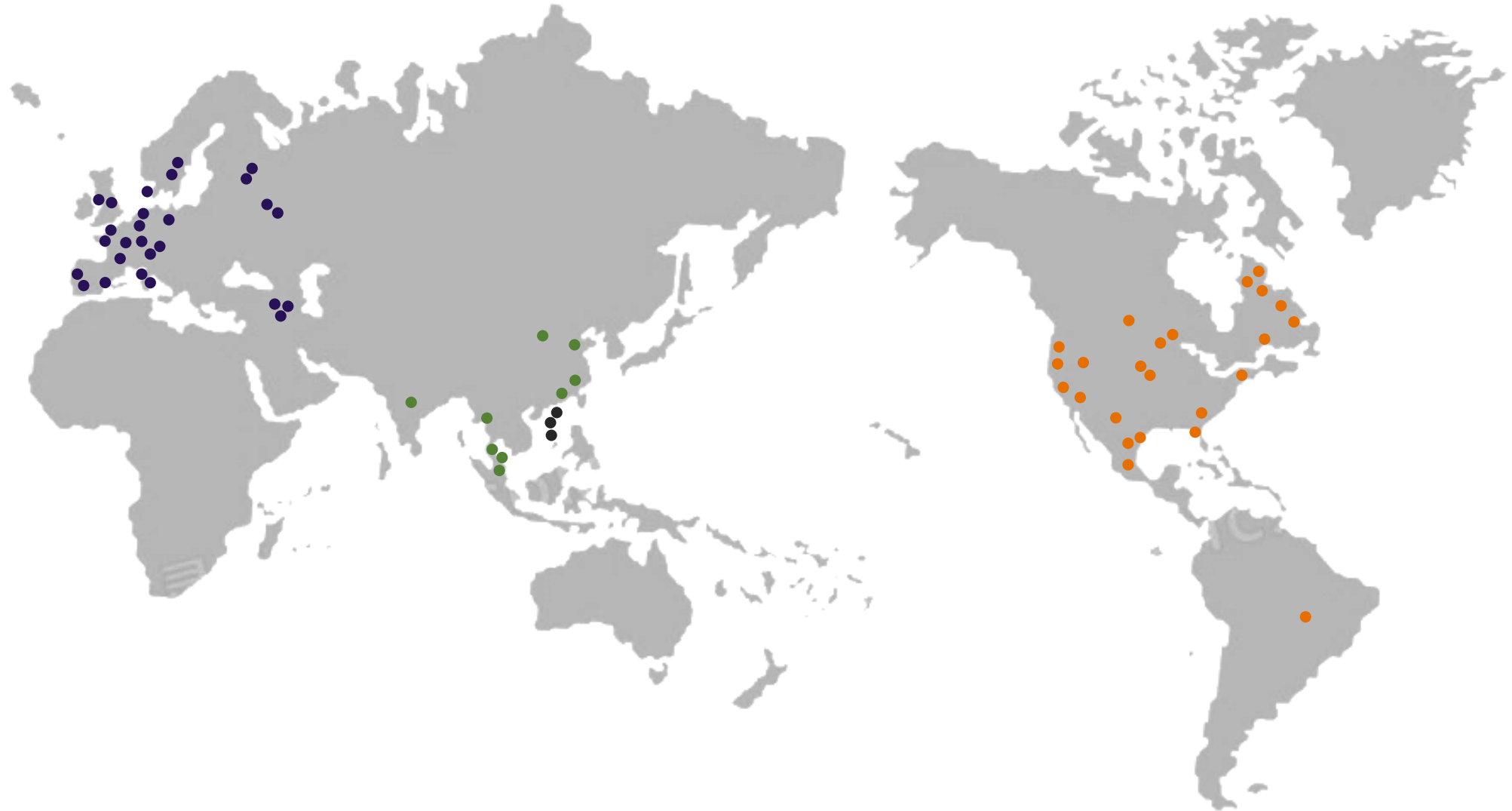

05

聯絡我們

更多詳細資訊 歡迎造訪永弘源網站

www.averexcnc.com



092021 CH



04-2355-1899



sales@averexcnc.com



台中市西屯區工業區35路63號

感謝聆聽 敬請指教

